

Description of Specification

Non-interchangeable Type

	SME	25	EA	2	SS	F0
Series : SME						
Size : 15, 20, 25, 30, 35, 45						
Carriage type : Heavy load						
EA : Flange type, mounting either from top or bottom						
EB : Compact flange type, mounting either from top or bottom (Size only 15, 20, 25)						
SA : Square type						
SB/SV : Compact square type						
Ultra heavy load						
LEA : Flange type, mounting either from top or bottom						
LEB : Compact flange type, mounting either from top or bottom (Size only 15, 20, 25)						
LSA : Square type						
LSB/LSV : Compact square type						
Number of carriages per rail : 1, 2, 3 ...						
Dust protection option of carriage :						
No symbol, UU, SS, ZZ, DD, KK (refer to Dust Proof [B1-232])						
Preload : FC (Light Preload), F0 (Medium preload), F1 (Heavy preload)						
Code of special carriage : No symbol, A, B, ...						
Rail type : R (Counter-bore type), T (Tapped hole type)						
Rail length (mm)						
Rail hole pitch from start side (E1 , see Fig.7)						
Rail hole pitch to the end side (E2 , see Fig.7)						
Accuracy grade : N, H, P, SP, UP						
Code of special rail : No symbol, A, B ...						
Dust protection option of rail : No symbol, /CC, /MC, /MD ... (refer to Code of Contaminaiton for Rail [B1-233])						
Number of rails per axis : No symbol, II, III, IV ...						

+R 1000 -20 /20 P II

--	--	--	--	--	--	--

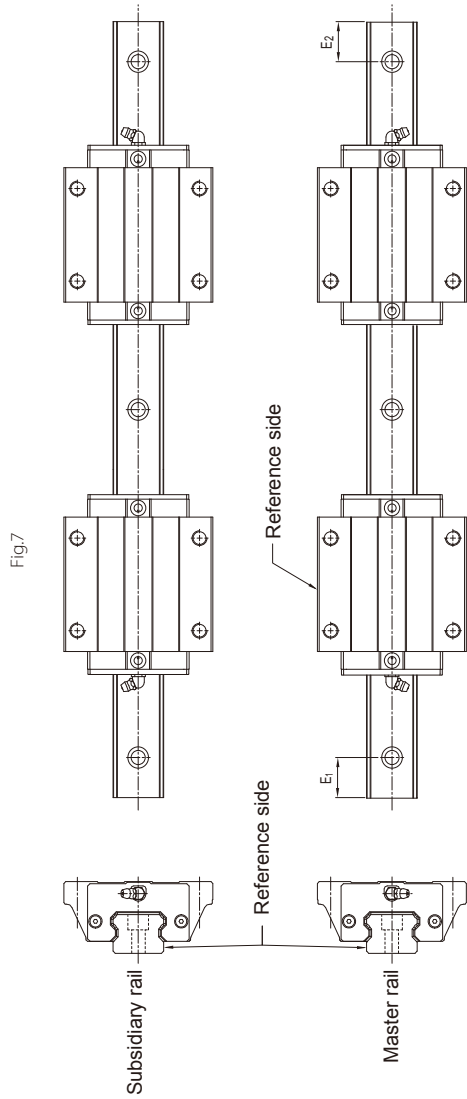

Interchangeable Type

Code of Carriage

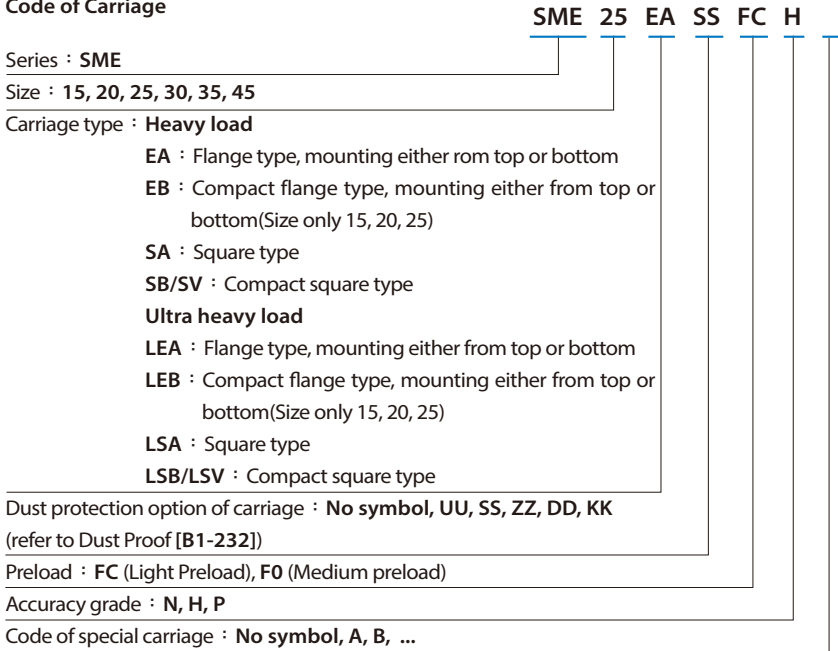

Code of Rail

